

Modulators

The modulator cable control is designed to send the engine throttle rate (on a mechanically governed engine) to the hydraulic control valve in the transmission. It will fit Allison® Transmission models AT500, MT600, HT700, V730, CLT650, and CLBT750 series.

SPECIFICATIONS:

- Control Cable is polymer lined rated at 300° F (149° C)
- 4 inch bend radii minimum
- Built-in spring returns to idle
- Pull function recommended, but push also available
- Can be locally assembled via F.A.S.T. cable assembly distributors.



Modulator Slip Link Kit (shown at right)

The Felsted Slip-Link kit includes the necessary hardware for complete installation of the Felsted Kit to the engine fuel control lever. Kit includes a slotted slip-link, link pin, flatwasher, cotter pin and locknut. To order, see chart below.

Polymer Link Part No.	Thread Size	For Use With Modulator Part No.
56049-1	(3 Series) 10-32UNF-2A THD	2124, 2179, 2180
59049-2	(4 Series) 2528UNF-2ATHD	2220, 2225, 2230, 2235

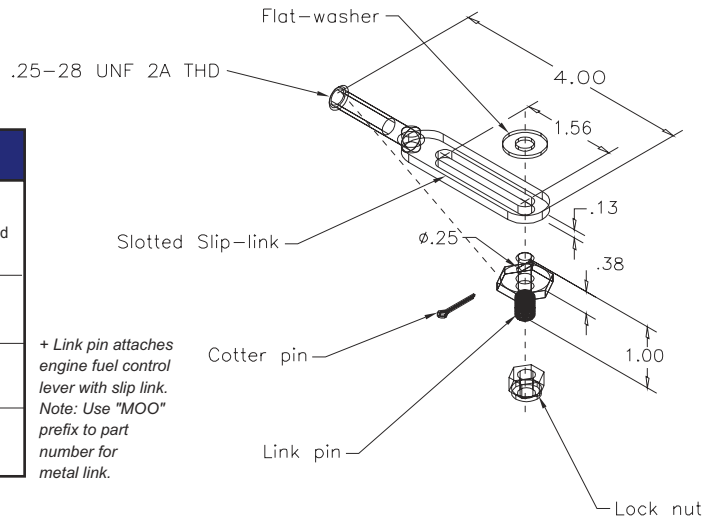

Pull Type	Description	Transmission
2124	Clamp 3-series end	FMX (threaded mount)
2179	Clamp 3-series end	C-6
2180	Bulkhead 3-series end	C-6
2182	Bulkhead 4-series end	Hydramatic (350/400)
2183	Clamp 4-series end	Hydramatic (350/400)
2220	Bulkhead 4-series end	Allison
2230	Clamp 4-series end	Allison

Push Type	Description	Transmission
2225	Bulkhead 4-series end	Allison
2235	Clamp 4-series end	Allison

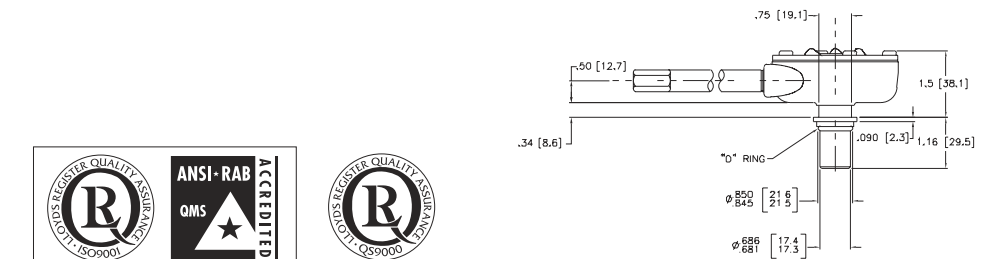
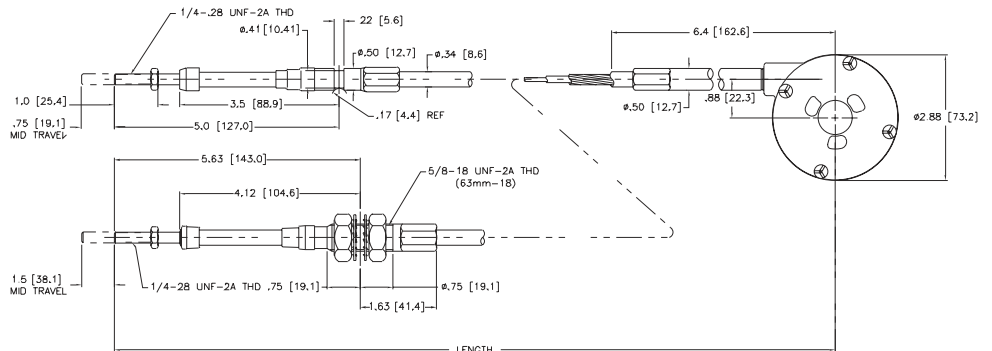

Specifications subject to change without notice.

USA

CANADA



UK

AUSTRALIA